

VENTURE
T R A I L E R S

2025-2026 Pricing

Release 6/16/2025

Venture Trailers
5301 North Point Blvd.
Baltimore, MD 21219
www.venturetrailers.com
info@venturetrailers.com
Phone: (410) 388-1000
Fax: (410) 388-1810





STATE BRAKE REQUIREMENTS-State laws require dealers to sell trailers that comply with the braking requirements where the trailer will be registered. Please contact the appropriate Motor Vehicle Department for compliance information.

Aluminum Bunk Trailers

Model	Capacity	*Boat Length	Galvanized Wheel Price	Aluminum Wheel Price	Overall Length	Bow Eye to Transom Minimum	Bow Eye to Transom Maximum	GVWR	Tongue Jack	# of Axles	Brakes	Tire Size	Overall Width	Between Fenders
VAB-1025	1025	12'-14'	\$CALL	\$CALL	15'	8'2"	12'8"	1230	Optional	1	NO	4.80 x 12 LRC 5H	60"	42"
VAB-1325	1325	14'-15'	\$CALL	\$CALL	18'1"	8'6"	15'6"	1535	Optional	1	NO	4.80 x 12 LRC 5H	60"	42"
VAB-2025	2025	16'-17'	\$CALL	\$CALL	20'3"	13'	18'	2485	Optional	1	NO	ST175/80R 13 LRC 5H	93"	76"
VAB-2425	2425	16'-18'	\$CALL	\$CALL	19'10"	14'	18'	2985	Optional	1	Optional	ST185/80R 13 LRD 5H	89"	71"
VAB-2625	2625	17'-19'	\$CALL	\$CALL	19'10"	14'	18'	3185	Optional	1	Optional	ST205/75R 14 LRC 5H	89"	71"
VAB-2825	2825	18'-20'	\$CALL	\$CALL	22'1"	16'	20'	3525	Optional	1	Optional	ST205/75R 14 LRC 5H	100"	81"
VAB-3025	3025	18'-20'	\$CALL	\$CALL	22'10"	16'	20'	3725	Single Wheel	1	Disc	ST215/75R 14 LRC 5H	100"	81"
VAB-3325	3325	20'-22'	\$CALL	\$CALL	24'	17'6"	21'	4100	Single Wheel	1	Disc	ST225/75R 15 LRD 6H	100"	81"
VAB-3525	3525	20'-22'	\$CALL	\$CALL	24'	17'6"	21'	4350	Single Wheel	1	Disc	ST225/75R 15 LRD 6H	100"	81"
VATB-3625	3625	18'-20'	\$CALL	\$CALL	22'10"	16'	20'	4585	Single Wheel	2	Disc-1	ST205/75R 14 LRC 5H	100"	81"
VATB-4225	4225	21'-22'	\$CALL	\$CALL	24'	17'6"	21'	5165	Single Wheel	2	Disc-1	ST205/75R 14 LRC 5H	100"	81"
VATB-5225	5225	21'-22'	\$CALL	\$CALL	24'	17'6"	21'	6165	Single Wheel	2	Disc-1	ST205/75R 14 LRC 5H	100"	81"
VATB-5925	5925	22'-24'	\$CALL	\$CALL	25'9"	18'8"	23'	6905	Flat Foot	2	Disc-1	ST205/75R 14 LRC 5H	100"	81"
VATB-6425	6425	24'-25'	\$CALL	\$CALL	27'7"	19'	24'	7555	Flat Foot	2	Disc-1	ST225/75R 15 LRD 6H	100"	81"
VATB-7225	7225	25'-26'	\$CALL	\$CALL	27'7"	19'	24'	8525	Flat Foot	2	Disc-1	ST225/75R 15 LRD 6H	100"	81"
VATB-8025	8025	25'-26'	\$CALL	\$CALL	30'1"	21'6"	26'	9365	Flat Foot	2	Disc-1	ST225/75R 15 LRD 6H	100"	81"
VATB-8725	8725	27'-29'	\$CALL	\$CALL	30'9"	21'6"	26'	10085	Flat Foot	2	Disc-1	ST225/75R 15 LRD 6H	100"	81"
VATB-9325	9325	27'-29'	\$CALL	\$CALL	31'7"	22'	28'	10845	Flat Foot	2	Disc-2	ST225/75R 15 LRE 6H	101"	81"
**Torsion Axles														
VATB-9625*	9625	27'-29'	\$CALL	\$CALL	31'7"	22'	28'	11425	Flat Foot	3	Disc-2	ST225/75R 15 LRD 6H	100"	81"
VATB-10625*	10625	27'-29'	\$CALL	\$CALL	31'7"	22'	28'	12425	Flat Foot	3	Disc-2	ST225/75R 15 LRD 6H	100"	81"
VATB-12625*	12625	29'-33'	\$CALL	\$CALL	37'	26'	31'	14485	Flat Foot	3	Disc-3	ST225/75R 15 LRD 6H	100"	81"
VATB-15025*	15025	32'-36'	\$CALL	\$CALL	39'11"	30'	35'	17505	Flat Foot	3	Disc-3	ST235/80R 16 LRE 8H	102"	82"
VATB-18025*	18025	32'-36'	\$CALL	\$CALL	39'11"	30'	35'	20555	Flat Foot	3	Disc-3	ST235/80R 16 LRE 8H	102"	82"

*All aluminum triple axle trailers come standard with **TARGET BUNKS**.

*Bow eye to drain plug measurements are the most accurate when fitting a boat to a trailer.

Popular Options

Add Tandem axle or Triple Axle Disc Brakes to trailers with "standard-1" or "standard-2" brakes	\$CALL
Target Bunks	\$CALL
Tongue Jack Swivel Wheel	\$CALL
Radial Windlass Anchor Bow Stop	\$CALL
Load guides 60" PVC	\$CALL

Venture Trailers is not responsible for boat/trailer set up unless specified at the time of order and proper boat specifications are provided. All trailers leave our factory at universal settings and require the dealer or operator to adjust the trailer to the boat it is accommodating. If boat specifications are provided by a manufacturer or dealer, certain set-ups and adjustments can be made during the time we manufacture your trailer(s). Please understand that the axle placement in accordance to tongue weight, bunk height/width placement, bunk position in accordance to transom to bow eye fit, winch stand assembly position and tongue jack placement may require adjustment even if specifications are provided.

COMMANDER

SERIES

PREMIUM ALUMINUM BUNK TRAILERS

Model	Price	Capacity	Boat Length*	Bow Eye to Drain Plug Minimum	Bow Eye to Drain Plug Maximum	Coupler Size	# of Axles	Brakes	Suspension	Tire Size	Overall Length	GVWR	Tongue Jack	Overall Width	Between Fenders
COM-2900	\$CALL	2900	18'-20'	16'	20'	2"	1	Optional	Torsion	ST205/75R 14 LRC 5H	22'1"	3600	Single Wheel	101"	83"
COM-3100	\$CALL	3100	18'-20'	16'	20'	2"	1	Disc-1	Torsion	ST215/75R 14 LRC 5H	22'10"	3800	Single Wheel	101"	83"
COM-3400	\$CALL	3400	20'-22'	17'6"	21'	2"	1	Disc-1	Torsion	ST225/75R 15 LRD 5H	24'	4175	Single Wheel	101"	83"
COM-3700	\$CALL	3700	18'-20'	16'	20'	2"	2	Disc-2	Torsion	ST205/75R 14 LRC 5H	22'10"	4650	Single Wheel	101"	83"
COM-5300	\$CALL	5300	20'-22'	17'6"	21'	2"	2	Disc-2	Torsion	ST205/75R 14 LRC 5H	24'	6250	Single Wheel	101"	83"
COM-6000	\$CALL	6000	22'-24'	18'8"	23'	2"	2	Disc-2	Torsion	ST205/75R 14 LRC 5H	25'9"	7050	Flat Foot	101"	83"
COM-6500	\$CALL	6500	24'-26'	19'	24'	2"	2	Disc-2	Torsion	ST225/75R 15 LRD 5H	27'7"	7800	Flat Foot	101"	83"
COM-7300	\$CALL	7300	24'-26'	19'	24'	2 5/16"	2	Disc-2	Torsion	ST225/75R 15 LRD 5H	27'7"	8600	Flat Foot	101"	83"
COM-8100	\$CALL	8100	25'-27'	21'6"	26'	2 5/16"	2	Disc-2	Torsion	ST225/75R 15 LRD 6H	30'1"	9440	Flat Foot	101"	83"
COM-8800	\$CALL	8800	27'-29'	21'6"	27'	2 5/16"	2	Disc-2	Torsion	ST225/75R 15 LRD 6H	30'9"	10160	Flat Foot	101"	83"
COM-10800	\$CALL	10800	28'-30'	22'	28'	2 5/16"	3	Disc-3	Torsion	ST225/75R 15 LRD 6H	31'7"	12730	Flat Foot	101"	83"
COM-12600	\$CALL	12600	29'-33'	26'	31'	2 5/16"	3	Disc-3	Torsion	ST225/75R 15 LRD 6H	37'1"	14610	Flat Foot	101"	83"

*Bow eye to drain plug measurements are the most accurate when fitting a boat to a trailer.

STANDARD FEATURES

- ⊕ ALUMINUM SPORT RIMS
- ⊕ LOAD GUIDES
- ⊕ BALANCED RADIAL TIRES
- ⊕ POLY SLEEVE
- ⊕ ALUMINUM DIAMOND PLATE FENDERS
- ⊕ GALVANIZED HARDWARE
- ⊕ ADJUSTABLE FORWARD TARGET BUNKS
- ⊕ DISC BRAKES ON ALL AXLES WITH GALVX COATING (1000HR SALT SPRAY TEST) (EXCEPT COM-2900)
- ⊕ VORTEX HUBS WITH 6 YEAR/ 100,000 MILE WARRANTY "NO TOUCH" LUBRICATION SYSTEM USING LUCAS PREMIUM MARINE GREASE
- ⊕ PLUG & PLAY LIGHTING
- ⊕ TONGUE JACK
- ⊕ HEAVY DUTY WINCH STRAP
- ⊕ PREMIUM LED LIGHTING
- ⊕ ALUMINUM CROSSMEMBERS
- ⊕ GALVANIZED TORSION AXLES
- ⊕ COMPOSITE BRAKELINE

STATE BRAKE REQUIREMENTS: STATE LAWS REQUIRE DEALERS TO SELL TRAILERS THAT COMPLY WITH THE BRAKING REQUIREMENTS WHERE THE TRAILERS WILL BE REGISTERED. PLEASE CONTACT THE APPROPRIATE MOTOR VEHICLE DEPARTMENT FOR COMPLIANCE INFORMATION.



STATE BRAKE REQUIREMENTS-State laws require dealers to sell trailers that comply with the braking requirements where the trailer will be registered. Please contact the appropriate Motor Vehicle Department for compliance information.

Aluminum Roller Trailers

Model	Capacity	*Boat Length	Galvanized Wheel Price	Aluminum Wheel Price	Overall Length	Bow Eye to Transom Minimum	Bow Eye to Transom Maximum	GVWR	Tongue Jack	# of Axles	Brakes	# of Rollers	Tire Size	Overall Width	Between Fenders
VAR-2425	2425	16'-18'	\$CALL	\$CALL	19'10"	14'	18'	2995	Optional	1	Optional	16	ST185/80R 13 LRD 5H	89"	71"
VAR-2625	2625	17'-19'	\$CALL	\$CALL	19'10"	14'	18'	3185	Optional	1	Optional	20	ST205/75R 14 LRC 5H	89"	71"
VAR-2825	2825	18'-20'	\$CALL	\$CALL	23'2"	16'	20'	3445	Optional	1	Optional	20	ST205/75R 14 LRC 5H	100"	81"
VAR-3025	3025	18'-20'	\$CALL	\$CALL	23'2"	16'	20'	3775	Single Wheel	1	Disc	20	ST215/75R 14 LRC 5H	100"	81"
VAR-3325	3325	20'-22'	\$CALL	\$CALL	24'1"	17'6"	21'	4150	Single Wheel	1	Disc	20	ST225/75R 15 LRD 6H	100"	81"
VAR-3525	3525	20'-22'	\$CALL	\$CALL	24'1"	17'6"	21'	4350	Single Wheel	1	Disc	20	ST225/75R 15 LRD 6H	100"	81"
VATR-3625	3625	18'-20'	\$CALL	\$CALL	23'6"	16'	20'	4575	Single Wheel	2	Disc-1	20	ST205/75R 14 LRC 5H	100"	81"
VATR-4225	4225	21'-22'	\$CALL	\$CALL	24'1"	17'6"	21'	5275	Single Wheel	2	Disc-1	24	ST205/75R 14 LRC 5H	100"	81"
VATR-5225	5225	21'-22'	\$CALL	\$CALL	24'1"	17'6"	21'	6275	Single Wheel	2	Disc-1	28	ST205/75R 14 LRC 5H	100"	81"
VATR-6025	6025	23'-24'	\$CALL	\$CALL	25'9"	18'10"	23'	7125	Flat Foot	2	Disc-1	44	ST205/75R 15 LRC 5H	100"	81"
VATR-6425	6425	24'-25'	\$CALL	\$CALL	27'7"	19'	24'	7755	Flat Foot	2	Disc-1	44	ST225/75R 15 LRD 6H	100"	81"

*Bow eye to drain plug measurements are the most accurate when fitting a boat to a trailer.

Popular Options

Add Tandem axle or Triple Axle Disc Brakes to trailers with "standard-1" or "standard-2" brakes	\$CALL
Target Bunks	\$CALL
Tongue Jack Swivel Wheel	\$CALL
Radial Windlass Anchor Bow Stop	\$CALL
Load guides 60" PVC	\$CALL

Venture Trailers is not responsible for boat/trailer set up unless specified at the time of order and proper boat specifications are provided. All trailers leave our factory at universal settings and require the dealer or operator to adjust the trailer to the boat it is accommodating. If boat specifications are provided by a manufacturer or dealer, certain set-ups and adjustments can be made during the time we manufacture your trailer(s). Please understand that the axle placement in accordance to tongue weight, bunk height/width placement, bunk position in accordance to transom to bow eye fit, winch stand assembly position and tongue jack placement may require adjustment even if specifications are provided.



STATE BRAKE REQUIREMENTS-State laws require dealers to sell trailers that comply with the braking requirements where the trailer will be registered. Please contact the appropriate Motor Vehicle Department for compliance information.

Galvanized Steel Bunk Trailers

Model	Capacity	*Boat Length	Galvanized Wheel Price	Aluminum Wheel Price	Overall Length	Bow Eye to Transom Minimum	Bow Eye to Transom Maximum	GVWR	Tongue Jack	# of Axles	Brakes	Tire Size	Overall Width	Between Fenders
VB-1000	1000	12'-14'	\$CALL	\$CALL	15'9"	8'6"	13'	1270	Optional	1	No	4.80 x 12 LRC 5H	60"	42"
VB-1300	1300	14'-15'	\$CALL	\$CALL	17'6"	8'6"	15'6"	1575	Optional	1	No	4.80 x 12 LRC 5H	60"	42"
VB-1500	1500	14'-15'	\$CALL	\$CALL	16'8"	10'6"	14'6"	1920	Optional	1	No	5.30 x 12 LRC 5H	78"	60"
VB-1800	1800	15'-16'	\$CALL	\$CALL	19'2"	10'6"	16'6"	2230	Optional	1	No	5.30 x 12 LRD 5H	78"	60"
VB-2000	2000	16'-17'	\$CALL	\$CALL	18'6"	14'	16'6"	2550	Optional	1	Optional	ST175/80R 13 LRC 5H	84"	67"
VB-2200	2200	17'-18'	\$CALL	\$CALL	19'4"	14'	17'6"	2750	Optional	1	Optional	ST185/80R 13 LRD 5H	84"	67"
VB-2400	2400	17'-18.5'	\$CALL	\$CALL	20'9"	14'	18'6"	3190	Optional	1	Optional	ST205/75R 14 LRC 5H	88"	67"
VB-2600	2600	18'-19'	\$CALL	\$CALL	21'10"	15'	18'	3380	Optional	1	Optional	ST205/75R 14 LRC 5H	100"	81"
VB-2800S	2800	18'-20'	\$CALL	\$CALL	21'10"	15'	18'	3580	Optional	1	Optional	ST205/75R 15 LRC 5H	100"	81"
VB-2800	2800	20'-21'	\$CALL	\$CALL	22'11"	16'	20'	3625	Optional	1	Optional	ST205/75R 15 LRC 5H	100"	81"
VB-3000S	3000	18'-20'	\$CALL	\$CALL	22'6"	15'	18'	3780	Single Wheel	1	Disc	ST215/75R 14 LRC 5H	100"	81"
VB-3100	3100	20'-21'	\$CALL	\$CALL	22'11"	16'	20'	3975	Single Wheel	1	Disc	ST215/75R 14 LRC 5H	100"	81"
VB-3300	3300	20'-21'	\$CALL	\$CALL	23'6"	16'	20'	4175	Single Wheel	1	Disc	ST225/75R 15 LRD 6H	100"	81"
VBT-3600S	3600	18'-20'	\$CALL	\$CALL	22'6"	15'	19'	4600	Single Wheel	2	Disc-1	ST205/75R 14 LRC 5H	100"	81"
VBT-3700	3700	21'-23'	\$CALL	\$CALL	25'5"	17'	21'	4750	Single Wheel	2	Disc-1	ST205/75R 14 LRC 5H	100"	81"
VBT-4200	4200	21'-23'	\$CALL	\$CALL	25'5"	17'	21'	5250	Single Wheel	2	Disc-1	ST205/75R 14 LRC 5H	100"	81"
VBT-4700	4700	21'-23'	\$CALL	\$CALL	25'5"	17'	21'	5750	Single Wheel	2	Disc-1	ST205/75R 14 LRC 5H	100"	81"
VBT-5200	5200	21'-23'	\$CALL	\$CALL	25'5"	17'	21'	6250	Single Wheel	2	Disc-1	ST205/75R 15 LRC 5H	100"	81"
VBT-5600	5600	21'-23'	\$CALL	\$CALL	25'5"	17'	21'	6650	Single Wheel	2	Disc-1	ST205/75R 15 LRC 5H	100"	81"
VBT-5900	5900	24'-25'	\$CALL	\$CALL	27'6"	19'	24'	7300	Flat Foot	2	Disc-1	ST215/75R 14 LRC 5H	100"	81"
VBT-6400	6400	25'-26'	\$CALL	\$CALL	28'11"	19'	24'	7825	Flat Foot	2	Disc-1	ST225/75R 15 LRD 6H	100"	81"
VBT-7400	7400	25'-27'	\$CALL	\$CALL	29'10"	19'	24'	8825	Flat Foot	2	Disc-1	ST225/75R 15 LRD 6H	100"	81"
VBT-7900	7900	25'-27'	\$CALL	\$CALL	29'10"	20'	25'	9350	Flat Foot	2	Disc-1	ST225/75R 15 LRD 6H	100"	81"
VBT-8600	8600	27'-28'	\$CALL	\$CALL	31'6"	22'	26'6"	10420	Flat Foot	3	Disc-2	ST205/75R 14 LRC 5H	100"	81"
VBT-9200	9200	28'-30'	\$CALL	\$CALL	32'11"	22'	28'	11040	Flat Foot	3	Disc-2	ST225/75R 15 LRD 6H	100"	81"
VBT-10800	10800	29'-31'	\$CALL	\$CALL	32'11"	22'	28'	12640	Flat Foot	3	Disc-2	ST225/75R 15 LRD 6H	100"	81"

*Bow eye to drain plug measurements are the most accurate when fitting a boat to a trailer.

Popular Options

Add Tandem axle or Triple Axle Disc Brakes to trailers with "standard-1" or "standard-2" brakes	\$CALL
Tongue Jack Swivel Wheel	\$CALL
Radial Windlass Anchor Bow Stop	\$CALL
Load guides 60" PVC	\$CALL

Venture Trailers is not responsible for boat/trailer set up unless specified at the

time of order and proper boat specifications are provided. All trailers leave our factory at universal settings and require the dealer or operator to adjust the trailer to the boat it is accommodating. If boat specifications are provided by a manufacturer or dealer, certain set-ups and adjustments can be made during the time we manufacture your trailer(s). Please understand that the axle placement in accordance to tongue weight, bunk height/width placement, bunk position in accordance to transom to bow eye fit, winch stand assembly position and tongue jack placement may require adjustment even if specifications are provided.



STATE BRAKE REQUIREMENTS-State laws require dealers to sell trailers that comply with the braking requirements where the trailer will be registered. Please contact the appropriate Motor Vehicle Department for compliance information.

Galvanized Steel Roller Trailers

Model	Capacity	*Boat Length	Galvanized Wheel Price	Aluminum Wheel Price	Overall Length	Bow Eye to Transom Minimum	Bow Eye to Transom Maximum	GVWR	Tongue Jack	# of Axles	Brakes	# of Rollers	Tire Size	Overall Width	Between Fenders
VR-1550	1550	14'-15'	\$CALL	\$CALL	16'5"	10'6"	14'6"	1950	Optional	1	No	12	5.30 x 12 LRC 5H	78"	60"
VR-1850	1850	15'-16'	\$CALL	\$CALL	19'3"	10'6"	16'6"	2250	Optional	1	No	12	5.30 x 12 LRD 5H	78"	60"
VR-2050	2050	16'-17'	\$CALL	\$CALL	19'	14'	16'6"	2625	Optional	1	Optional	12	ST175/80R 13 LRC 5H	84"	67"
VR-2250	2250	17'-18'	\$CALL	\$CALL	19'3"	14'	17'6"	2850	Optional	1	Optional	16	ST185/80R 13 LRD 5H	84"	67"
VR-2450	2450	17'-18.5'	\$CALL	\$CALL	20'7"	15'6"	18'6"	3250	Optional	1	Optional	16	ST205/75R 14 LRC 5H	88"	67"
VR-2650	2650	18'-19'	\$CALL	\$CALL	22'6"	16'	18'	3500	Optional	1	Optional	20	ST205/75R 14 LRC 5H	100"	81"
VR-2850S	2850	18'-20'	\$CALL	\$CALL	22'6"	16'	18'	3700	Optional	1	Optional	20	ST205/75R 15 LRC 5H	100"	81"
VR-2850	2850	20'-21'	\$CALL	\$CALL	22'11"	16'	20'	3700	Optional	1	Optional	20	ST205/75R 15 LRC 5H	100"	81"
VR-3050S	3050	18'-20'	\$CALL	\$CALL	22'6"	16'	18'	3850	Single Wheel	1	Disc	20	ST215/75R 14 LRC 5H	100"	81"
VR-3150	3150	20'-21'	\$CALL	\$CALL	22'11"	16'	20'	4075	Single Wheel	1	Disc	20	ST215/75R 14 LRC 5H	100"	81"
VR-3350	3350	20'-21'	\$CALL	\$CALL	23'6"	16'	20'	4275	Single Wheel	1	Disc	20	ST225/75R 15 LRD 6H	100"	81"
VRT-3650S	3650	18'-20'	\$CALL	\$CALL	22'6"	16'	19'	4650	Single Wheel	2	Disc-1	20	ST205/75R 14 LRC 5H	100"	81"
VRT-3750	3750	21'-23'	\$CALL	\$CALL	24'9"	17'	21'	4800	Single Wheel	2	Disc-1	20	ST205/75R 14 LRC 5H	100"	81"
VRT-4250	4250	21'-23'	\$CALL	\$CALL	24'9"	17'	21'	5350	Single Wheel	2	Disc-1	24	ST205/75R 14 LRC 5H	100"	81"
VRT-4750	4750	21'-23'	\$CALL	\$CALL	24'9"	17'	21'	5900	Single Wheel	2	Disc-1	28	ST205/75R 14 LRC 5H	100"	81"
VRT-5250	5250	21'-23'	\$CALL	\$CALL	24'9"	17'	21'	6450	Single Wheel	2	Disc-1	32	ST205/75R 15 LRC 5H	100"	81"
VRT-5650	5650	21'-23'	\$CALL	\$CALL	24'9"	17'	21'	6850	Single Wheel	2	Disc-1	32	ST205/75R 15 LRC 5H	100"	81"
VRT-5950	5950	24'-25'	\$CALL	\$CALL	27'6"	19'	24'	7450	Flat Foot	2	Disc-1	44	ST215/75R 14 LRC 5H	100"	81"
VRT-6450	6450	25'-26'	\$CALL	\$CALL	27'6"	19'	24'	7975	Flat Foot	2	Disc-1	52	ST225/75R 15 LRD 6H	100"	81"
VRT-7450	7450	25'-27'	\$CALL	\$CALL	28'5"	19'	24'	9000	Flat Foot	2	Disc-1	60	ST225/75R 15 LRD 6H	100"	81"
VRT-7950	7950	25'-27'	\$CALL	\$CALL	28'5"	20'	25'	9550	Flat Foot	2	Disc-1	64	ST225/75R 15 LRD 6H	100"	81"
VRT-8650	8650	27'-28'	\$CALL	\$CALL	31'6"	22'	27'6"	10450	Flat Foot	3	Disc-2	64	ST205/75R 14 LRC 5H	100"	81"
VRT-9250	9250	28'-30'	\$CALL	\$CALL	32'11"	22'	29'	11050	Flat Foot	3	Disc-2	64	ST225/75R 15 LRD 6H	100"	81"
VRT-10850	10850	29'-31'	\$CALL	\$CALL	32'11"	22'	29'	12750	Flat Foot	3	Disc-2	64	ST225/75R 15 LRD 6H	100"	81"

*Bow eye to drain plug measurements are the most accurate when fitting a boat to a trailer.

Popular Options

Add Tandem axle or Triple Axle Disc Brakes to trailers with "standard-1" or "standard-2" brakes	\$CALL
Tongue Jack Swivel Wheel	\$CALL
Radial Windlass Anchor Bow Stop	\$CALL
Load guides 60" PVC	\$CALL

Venture Trailers is not responsible for boat/trailer set up unless specified at the

time of order and proper boat specifications are provided. All trailers leave our factory at universal settings and require the dealer or operator to adjust the trailer to the boat it is accommodating. If boat specifications are provided by a manufacturer or dealer, certain set-ups and adjustments can be made during the time we manufacture your trailer(s). Please understand that the axle placement in accordance to tongue weight, bunk height/width placement, bunk position in accordance to transom to bow eye fit, winch stand assembly position and tongue jack placement may require adjustment even if specifications are provided.



STATE BRAKE REQUIREMENTS-State laws require dealers to sell trailers that comply with the braking requirements where the trailer will be registered. Please contact the appropriate Motor Vehicle Department for compliance information.

Galvanized Steel Pontoon Trailers

Model	Capacity	*Boat Length	Galvanized Wheel Price	Aluminum Wheel Price	Overall Length	Minimum Ctr to Ctr Bunk Width	Maximum Ctr to Ctr Bunk Width	GVWR	Tongue Jack	# of Axles	Brakes	Tire Size	Overall Width	Between Fenders
VP-18-20	2000	17'-19'	\$CALL	\$CALL	23' 3"	72"	80"	2760	Optional	1	Optional	ST175 80R 13LRD	98"	78"
VP-18-27	2700	17'-19'	\$CALL	\$CALL	23'3"	72"	80"	3440	Optional	1	Optional <small>*Highly recommend brakes!</small>	ST215 75R 14LRC	98"	78"
VPT-18-32	3200	17'-19'	\$CALL	\$CALL	23'3"	72"	80"	4240	Single Wheel	2	Disc-1	ST175 80R 13LRC	98"	78"
VP-20-20	2000	19'-21'	\$CALL	\$CALL	25' 3"	72"	80"	2780	Optional	1	Optional	ST175 80R 13 LRD	98"	78"
VP-20-25	2500	19'-21'	\$CALL	\$CALL	25' 3"	72"	80"	3280	Optional	1	Optional	ST185 80R 13LRD	98"	78"
VP-20-27	2700	19'-21'	\$CALL	\$CALL	25' 3"	72"	80"	3380	Optional	1	Optional <small>*Highly recommend brakes!</small>	ST215 75R 14LRC	98"	78"
VP-22-25	2500	19'-22'	\$CALL	\$CALL	26' 3"	72"	80"	3305	Optional	1	Optional	ST185 80R 13LRD	98"	78"
VP-22-27	2700	19'-22'	\$CALL	\$CALL	26' 3"	72"	80"	3505	Optional	1	Optional <small>*Highly recommend brakes!</small>	ST215 75R 14LRC	98"	78"
VPT-22-32	3200	19'-22'	\$CALL	\$CALL	26' 3"	72"	80"	4180	Single Wheel	2	Disc-1	ST175 80R 13LRC	98"	78"
VPT-22-40	4000	19'-22'	\$CALL	\$CALL	26' 3"	72"	80"	5120	Single Wheel	2	Disc-1	ST175 80R 13LRC	98"	78"
VPT-22-50	5000	19'-22'	\$CALL	\$CALL	26' 3"	72"	80"	6120	Single Wheel	2	Disc-1	ST185 80R 13LRD	98"	78"
VP-24-25	2500	23'-25'	\$CALL	\$CALL	31'	72"	80"	3440	Optional	1	Optional	ST185 80R 13LRD	98"	78"
VP-24-27	2700	23'-25'	\$CALL	\$CALL	31'	72"	80"	3580	Optional	1	Optional <small>*Highly recommend brakes!</small>	ST215 75R 14LRC	98"	78"
VPT-24-40	4000	23'-25'	\$CALL	\$CALL	31'	72"	80"	5140	Single Wheel	2	Disc-1	ST175 80R 13LRC	98"	78"
VPT-24-50	5000	23'-25'	\$CALL	\$CALL	31'	72"	80"	6160	Single Wheel	2	Disc-1	ST185 80R 13LRD	98"	78"
VPT-26-40	4000	23'-26'	\$CALL	\$CALL	32'	72"	80"	5160	Single Wheel	2	Disc-1	ST175 80R 13LRC	98"	78"
VPT-26-50	5000	23'-26'	\$CALL	\$CALL	32'	72"	80"	6160	Single Wheel	2	Disc-1	ST185 80R 13LRD	98"	78"
VPT-26-65	6500	23'-26'	\$CALL	\$CALL	32' 6"	72"	80"	8100	Flat Foot	3	Disc-2	ST175 80R 13LRC	98"	78"

Popular Options

Tongue Jack Swivel Wheel	\$CALL	Articulating Bunks VP-18-20, VP-20-20, VP-20-25	\$CALL
Add Disc Brakes	\$CALL	Articulating Bunks VP-22-25 thru VPT-26-65	\$CALL
Add Second Axle Disc Brakes	\$CALL	Offset Brackets for greater min/max center to center bunk width.	\$CALL
Add Second Non-Braking Axle to Single Axle Trailers	\$CALL	*Minimum center to center 64" to Maximum center to center 90"	
**If requesting 10" or 12" tires please inquire for brake upcharge		Manitow Set Up * Please contact sales for price	

Save Money \$\$

Remove Pontoon Load Guides	-\$CALL
Remove Poly Sleeve for Carpeted Bunks	-\$CALL

Standard on all models:

- *Steps with Handrail
- *Inside Load Guides
- *Poly Bunk Covers

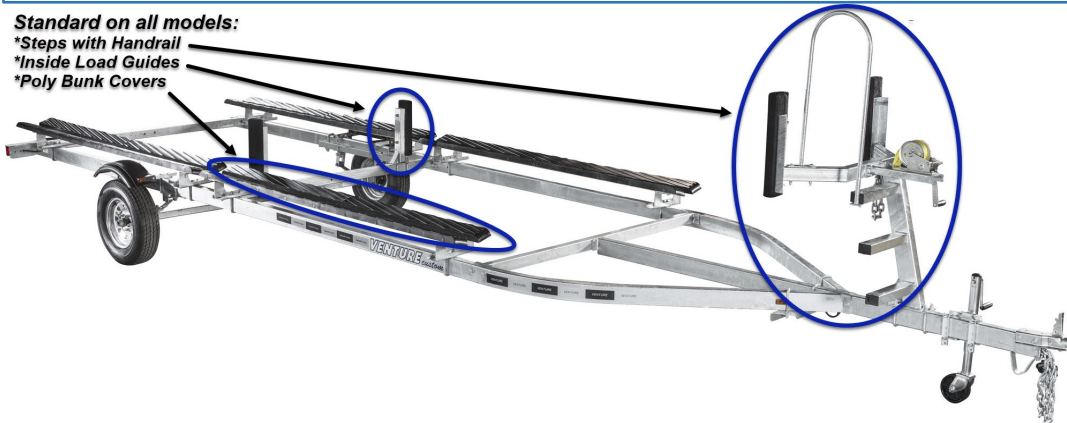

Venture Trailers is not responsible for boat/trailer set up unless specified at the time of order and proper boat specifications are provided. All trailers leave our factory at universal settings and require the dealer or operator to adjust the trailer to the boat it is accommodating. If boat specifications are provided by a manufacturer or dealer, certain set-ups and adjustments can be made during the time we manufacture your trailer(s). Please understand that the axle placement in accordance to tongue weight, bunk height/width placement, bunk position in accordance to transom to bow eye fit, winch stand assembly position and tongue jack placement may require adjustment even if specifications are provided.



STATE BRAKE REQUIREMENTS-State laws require dealers to sell trailers that comply with the braking requirements where the trailer will be registered. Please contact the appropriate Motor Vehicle Department for compliance information.

Galvanized Steel Tritoon Trailers

Model	Capacity	*Boat Length	Galvanized Wheel Price	Aluminum Wheel Price	Overall Length	Minimum Ctr to Ctr Bunk Width	Maximum Ctr to Ctr Bunk Width	GVWR	Tongue Jack	# of Axles	Brakes	Tire Size	Overall Width	Between Fenders
VP-18-20TRI	2000	17'-19'	\$CALL	\$CALL	23' 3"	72"	80"	2840	Optional	1	Optional	ST175 80R 13LRD	98"	78"
VP-18-27TRI	2700	17'-19'	\$CALL	\$CALL	23'3"	72"	80"	3588	Optional	1	Optional <small>*Highly recommend brakes!</small>	ST215 75R 14LRC	98"	78"
VPT-18-32TRI	3200	17'-19'	\$CALL	\$CALL	23'3"	72"	80"	4285	Single Wheel	2	Disc-1	ST175 80R 13LRC	98"	78"
VP-20-20TRI	2000	19'-21'	\$CALL	\$CALL	25' 3"	72"	80"	2860	Optional	1	Optional	ST175 80R 13LRD	98"	78"
VP-20-25TRI	2500	19'-21'	\$CALL	\$CALL	25' 3"	72"	80"	3330	Optional	1	Optional	ST185 80R 13LRD	98"	78"
VP-20-27TRI	2700	19'-21'	\$CALL	\$CALL	25' 3"	72"	80"	3520	Optional	1	Optional <small>*Highly recommend brakes!</small>	ST215 75R 14LRC	98"	78"
VP-22-25TRI	2500	19'-22'	\$CALL	\$CALL	26' 3"	72"	80"	3500	Optional	1	Optional	ST185 80R 13LRD	98"	78"
VP-22-27TRI	2700	19'-22'	\$CALL	\$CALL	26' 3"	72"	80"	3720	Optional	1	Optional <small>*Highly recommend brakes!</small>	ST215 75R 14LRC	98"	78"
VPT-22-32TRI	3200	19'-22'	\$CALL	\$CALL	26' 3"	72"	80"	4280	Single Wheel	2	Disc-1	ST175 80R 13LRC	98"	78"
VPT-22-40TRI	4000	19'-22'	\$CALL	\$CALL	26' 3"	72"	80"	5200	Single Wheel	2	Disc-1	ST175 80R 13LRC	98"	78"
VPT-22-50TRI	5000	19'-22'	\$CALL	\$CALL	26' 3"	72"	80"	6160	Single Wheel	2	Disc-1	ST185 80R 13LRD	98"	78"
VP-24-25TRI	2500	22'-25'	\$CALL	\$CALL	31'	72"	80"	3520	Optional	1	Optional	ST185 80R 13LRD	98"	78"
VP-24-27TRI	2700	22'-25'	\$CALL	\$CALL	31'	72"	80"	3560	Optional	1	Optional <small>*Highly recommend brakes!</small>	ST215 75R 14LRC	98"	78"
VPT-24-40TRI	4000	23'-25'	\$CALL	\$CALL	31'	72"	80"	5220	Single Wheel	2	Disc-1	ST175 80R 13LRC	98"	78"
VPT-24-50TRI	5000	23'-25'	\$CALL	\$CALL	31'	72"	80"	6260	Single Wheel	2	Disc-1	ST185 80R 13LRD	98"	78"
VPT-26-40TRI	4000	23'-26'	\$CALL	\$CALL	32'	72"	80"	5240	Single Wheel	2	Disc-1	ST175 80R 13LRC	98"	78"
VPT-26-50TRI	5000	23'-26'	\$CALL	\$CALL	32'	72"	80"	6240	Single Wheel	2	Disc-1	ST185 80R 13LRD	98"	78"
VPT-26-65TRI	6500	23'-26'	\$CALL	\$CALL	32' 6"	72"	80"	8150	Flat Foot	3	Disc-2	ST175 80R 13LRC	98"	78"

Popular Options

Tongue Jack Swivel Wheel	\$CALL	Articulating Bunks VP-18-20, VP-20-20, VP-20-25	\$CALL
Add Disc Brakes	\$CALL	Articulating Bunks VP-22-25 thru VPT-26-65	\$CALL
Add Second Axle Disc Brakes	\$CALL	Add Second Non-Braking Axle to Single Axle Trailers	\$CALL
		Manitou Set Up * Please contact sales for price	

**If requesting 10" or 12" tires please inquire for brake upcharge

Save Money \$\$

Remove Pontoon Load Guides	-\$CALL
Remove Poly Sleeve for Carpeted Bunks	-\$CALL

Standard on all models:

- *Steps with Handrail
- *Inside Load Guides
- *Poly Bunk Covers

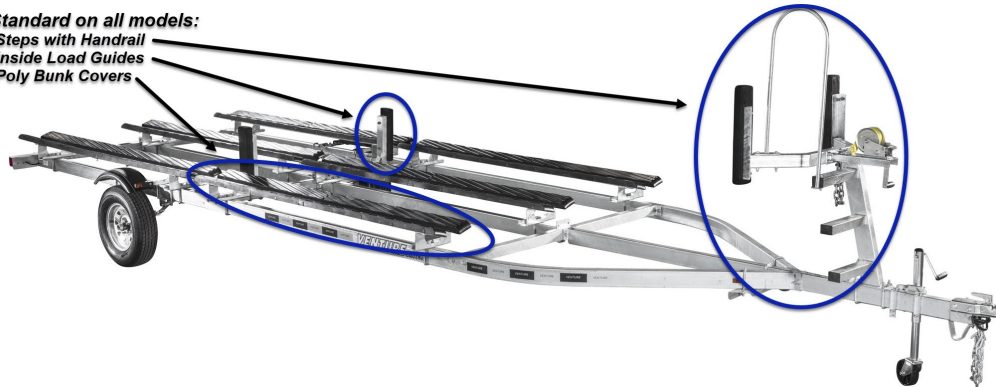

Venture Trailers is not responsible for boat/trailer set up unless specified at the time of order and proper boat specifications are provided. All trailers leave our factory at universal settings and require the dealer or operator to adjust the trailer to the boat it is accommodating. If boat specifications are provided by a manufacturer or dealer, certain set-ups and adjustments can be made during the time we manufacture your trailer(s). Please understand that the axle placement in accordance to tongue weight, bunk height/width placement, bunk position in accordance to transom to bow eye fit, winch stand assembly position and tongue jack placement may require adjustment even if specifications are provided.



STATE BRAKE REQUIREMENTS-State laws require dealers to sell trailers that comply with the braking requirements where the trailer will be registered. Please contact the appropriate Motor Vehicle Department for compliance information.

Model	Capacity	*Boat Length	Galvanized Wheel Price	Aluminum Wheel Price	Overall Length	Bow Eye to Transom Minimum	Bow Eye to Transom Maximum	GVWR	Tongue Jack	# of Axles	Brakes	Tire Size	Overall Width	Between Fenders
VASK-1800	1800	15'-17'	\$CALL	\$CALL	19'10"	14'4"	17'10"	2290	Optional	1	No	5.30 x 12 LRD 5H	85"	65"
VASK-2100	2100	15'-17'	\$CALL	\$CALL	21'8"	14'	18'	2630	Optional	1	No	ST175/80R 13 LRC 5H	89"	70"
VASK-2300	2300	16'-18'	\$CALL	\$CALL	21'8"	14'	18'	2830	Optional	1	Optional	ST185/80R 13 LRD 5H	89"	70"
VASK-2500	2500	17'-19'	\$CALL	\$CALL	21'8"	14'	18'	3050	Optional	1	Optional	ST185/80R 13 LRD 5H	100"	81"
VASK-2800	2800	18'-21'	\$CALL	\$CALL	23'6"	17'	20'6"	3380	Optional	1	Optional	ST205/75R 14 LRC 5H	100"	81"
VASK-3200	3200	19'-21'	\$CALL	\$CALL	23'6"	17'	20'6"	3800	Single Wheel	1	Disc	ST225/75R 15 LRD 6H	100"	81"
VASK-4200S	4200	21'-22'	\$CALL	\$CALL	24'6"	17'	21'	5040	Single Wheel	2	Disc-1	ST205/75R 14 LRC 5H	100"	81"
VASK-4200	4200	22'-23'	\$CALL	\$CALL	26'6"	17'	23'	5120	Single Wheel	2	Disc-1	ST205/75R 14 LRC 5H	100"	81"

Aluminum Jon Boat Trailers

Model	Capacity	*Boat Length	Galvanized Wheel Price	Aluminum Wheel Price	Overall Length	Bow Eye to Transom Minimum	Bow Eye to Transom Maximum	GVWR	Tongue Jack	# of Axles	Brakes	Tire Size	Overall Width	Between Fenders
VAB-1025	1025	12'-14'	\$CALL	\$CALL	15'	8'2"	12'8"	1230	Optional	1	NO	4.80 x 12 LRC 5H	60"	42"
VAB-1325	1325	14'-15'	\$CALL	\$CALL	18'1"	8'6"	15'6"	1535	Optional	1	NO	4.80 x 12 LRC 5H	60"	42"

Galvanized Jon Boat Trailers

Model	Capacity	*Boat Length	Galvanized Wheel Price	Aluminum Wheel Price	Overall Length	Bow Eye to Transom Minimum	Bow Eye to Transom Maximum	GVWR	Tongue Jack	# of Axles	Brakes	Tire Size	Overall Width	Between Fenders
VB-1000	1000	12'-14'	\$CALL	\$CALL	15'9"	8'6"	13'	1270	Optional	1	No	4.80 x 12 LRC 5H	60"	42"
VB-1300	1300	14'-15'	\$CALL	\$CALL	17'6"	8'6"	15'6"	1575	Optional	1	No	4.80 x 12 LRC 5H	60"	42"
VB-1500	1500	14'-15'	\$CALL	\$CALL	16'8"	10'6"	14'6"	1920	Optional	1	No	5.30 x 12 LRC 5H	78"	60"
VB-1800	1800	15'-16'	\$CALL	\$CALL	19'2"	10'6"	16'6"	2230	Optional	1	No	5.30 x 12 LRD 5H	78"	60"

Galvanized Inflatable Trailers

Model	Capacity	*Boat Length	Galvanized Wheel Price	Aluminum Wheel Price	Overall Length	Bow Eye to Transom Minimum	Bow Eye to Transom Maximum	GVWR	Tongue Jack	# of Axles	Brakes	Tire Size	Overall Width	Between Fenders
VINF-1000	1000	12'-14'	\$CALL	\$CALL	15'9"	8'6"	13'	1270	Optional	1	No	4.80 x 12 LRC 5H	60"	42"
VINF-1300	1300	14'-15'	\$CALL	\$CALL	17'6"	8'6"	15'6"	1570	Optional	1	No	4.80 x 12 LRC 5H	60"	42"

*Bow eye to drain plug measurements are the most accurate when fitting a boat to a trailer.

Popular Options

Tongue Jack Swivel Wheel	\$CALL
Load guides 60" PVC	\$CALL

Venture Trailers is not responsible for boat/trailer set up unless specified at the time of order and proper boat specifications are provided.

All trailers leave our factory at universal settings and require the dealer or operator to adjust the trailer to the boat it is accommodating. If boat specifications are provided by a manufacturer or dealer, certain set-ups and adjustments can be made during the time we manufacture your trailer(s). Please understand that the axle placement in accordance to tongue weight, bunk height/width placement, bunk position in accordance to transom to bow eye fit, winch stand assembly position and tongue jack placement may require adjustment even if specifications are provided.



STATE BRAKE REQUIREMENTS-State laws require dealers to sell trailers that comply with the braking requirements where the trailer will be registered. Please contact the appropriate Motor Vehicle Department for compliance information.

Aluminum Watercraft Trailers

Model	Capacity		Galvanized Wheel Price	Aluminum Wheel Price	Overall Length	GVWR	Tongue Jack	# of Axles	Brakes	Between Fenders	Overall Width	Tire Size
VAW-1200 <small>*straight crossmembers</small>	1200	2/3 Seater	\$CALL	\$CALL	14'3"	1380	Optional	1	No	42"	60"	4.80 x 12 LRC 5H
VADW-2000	2000	(2) 10'-12" PWCs	\$CALL	\$CALL	17'2"	2420	Optional	1	Optional	85"	102"	5.30 x 12 LRD 5H
VADW-2600	2600	(2) 10'-12" PWCs	\$CALL	\$CALL	18'7"	3160	Optional	1	Optional	85"	102"	20.5 X 8.0 X 10 LRF 5H

Galvanized Watercraft Trailers

Model	Capacity		Galvanized Wheel Price	Aluminum Wheel Price	Overall Length	GVWR	Tongue Jack	# of Axles	Brakes	Between Fenders	Overall Width	Tire Size
VW-1200	1200	2/3 Seater	\$CALL	\$CALL	13'	1420	Optional	1	No	42"	60"	4.80 x 12 LRC 5H
VW-2000	2000	Double	\$CALL	\$CALL	18'	2420	Optional	1	Optional	84"	102"	20.5 X 8.0 X 10 LRD 5H

Popular Options

Tongue Jack Swivel Wheel	\$CALL
Load guides 60" PVC	\$CALL

Venture Trailers is not responsible for boat/trailer set up unless specified at the time of order and proper boat specifications are provided. All trailers leave our factory at universal settings and require the dealer or operator to adjust the trailer to the boat it is accommodating. If boat specifications are provided by a manufacturer or dealer, certain set-ups and adjustments can be made during the time we manufacture your trailer(s). Please understand that the axle placement in accordance to tongue weight, bunk height/width placement, bunk position in accordance to transom to bow eye fit, winch stand assembly position and tongue jack placement may require adjustment even if specifications are provided.



Popular Options

Bunk Options

Part #

Target Bunks *(not available on steel trailers)*

Target Bunks 2x6x4' Carpeted <i>(standard with 10" stalk)</i>	\$CALL	
Target Bunk 12" Stalk Upgrade	\$CALL	
Target Bunk 14" Stalk Upgrade	\$CALL	
Poly Sleeve on Target bunks (up to 6')	\$CALL	
Poly Sleeve on Target bunks (>6')	\$CALL	

Poly Sleeve

Jon Boat/Skiff Trailers	\$CALL	
Watercraft Trailers-Single PWC	\$CALL	
Watercraft Trailers-Double PWC's	\$CALL	
Single Axle Bunk Trailers	\$CALL	
Tandem Axle Bunk Trailers	\$CALL	
Triple Axle Bunk Trailers	\$CALL	

Bunk Bracket Upgrades for 3x8, 3x10 Beam Style Bunks

10" Bunk Bracket <i>(light duty)</i> -single, tandem, triple axle trailers (EXCEPT VATB-15025 & VATB-18025)	\$CALL	
10" Bunk Bracket <i>(light duty)</i> -VATB-15025 & VATB-18025	\$CALL	
<i>We also offer a 10" bunk bracket for heavy duty applications. Please inquire for pricing.</i>		
12" Bunk Bracket-2425lbs-5925lbs. Trailer capacity	\$CALL	
12" Bunk Bracket-6425lbs.-12625lbs. Trailer capacity	\$CALL	
12" Bunk Bracket-VATB-15025 & VATB-18025	\$CALL	

Step Hull Bunks

Single Step	\$CALL	
Double Step	\$CALL	

Stainless Steel Hardware

Stainless Steel Hardware Upgrade-Single Axle Trailer (2000 weight capacity and up)	\$CALL	
Stainless Steel Hardware Upgrade-Tandem Axle Trailer	\$CALL	
Stainless Steel Hardware Upgrade-Triple Axle Trailer	\$CALL	

Keel Support Options

Radial Windlass Anchor Bow Stop	\$CALL	
Keel Roller Assembly- 12" (each)	\$CALL	
Keel Pads (each)	\$CALL	

Tongue and Tongue Jack Options		Part #
Extended Tongue		
0-1' extended tongue (please check available lengths)	\$CALL	
2' extended tongue (please check available lengths)	\$CALL	
Swing Tongues		
Swing Tongue-all trailers up to 6025lbs. Capacity	\$CALL	
<i>*If the trailer you are putting a swing tongue on comes with a single wheel swivel jack we recommend upgrading to a dual wheel tongue jack or foot jack. Tongue jack prices below.</i>		
Tongue Jacks		
1200lb. Single Wheel Swivel Tongue Jack Travel: 11"/Maximum Tongue Height: 25"	\$CALL	
1500lb. Dual Wheel Swivel Tongue Jack Travel: 12"/Maximum Tongue Height 28"	\$CALL	
2000lb. Drop Leg Tongue Jack with Foot (non-swivel) Travel: 30"/Maximum Tongue Height 38"	\$CALL	
Upgrade Pricing: trailers that come standard with single wheel swivel jacks can be upgraded to our 1500lb. dual wheel swivel jack or 2000lb drop leg jack with foot.	\$CALL	
Brake Options		
Disc Brakes		
Disc Brakes- <i>if trailer does not include brakes</i>	\$CALL	
Tandem Axle Disc Brakes- <i>if trailer has 1 set of brakes standard</i>	\$CALL	
Triple Axle Disc Brakes- <i>if trailer has 2 sets of brakes standard</i>	\$CALL	
Disc Brake Deduction- <i>if trailer has 1 set of brakes standard</i>	-\$CALL	
Disc Brake Deduction for 1 set of brakes if the trailer has 2 or 3 sets of brakes standard	-\$CALL	
Stainless Steel Brakes		
Stainless Disc Brake Upgrade-per braking axle	\$CALL	
Stainless Steel Brakelines		
Stainless Steel Brake Line Package-Tandem axle	\$CALL	
Stainless Steel Brake Line Package-Triple axle	\$CALL	
Electric Over Hydraulic Brakes		
Electric Over Hydraulic Brakes-up to 6500lbs. Trailer capacity <i>*in-cab controller NOT INCLUDED</i>	\$CALL	
Electric Over Hydraulic Brakes- 7225lbs.+ Trailer capacity <i>*in-cab controller NOT INCLUDED</i>	\$CALL	
Hydrastar EOH CAM Adapter- required for Ford model year 2007-2008 and GM/Chevy 2007-2016	\$CALL	20384
Load Guide Options		
Load Guides (PVC) 60" Height x 15" Width	\$CALL	
Load Guides (PVC) 75" Height x 33" Width <i>*recommended for 6000lbs.+ capacity trailers</i>	\$CALL	
Skiff Style-2x6x4' Carpeted Board Load Guides	\$CALL	

Spare Tire Carrier Options		Part #
Spare Tire Bracket- fits trailer tongues up to 3" wide and 5" high . Adjustable bolt circle to fit most 4 lug, 5 lug and 6 lug wheels and holds up to 16.5" wheels.	\$CALL	86015
Spare Tire Bracket fits all trailer frames up to 6" high . Accommodates 4, 5,6, 8 lug wheels. *Required for VATB-15025 & VATB-18025	\$CALL	86016
Spare Tire Carrier with spindle/hub-includes 1750lb hub and spindle	\$CALL	86026
Spare Tire Carrier with spindle/hub-includes 3000lb hub and spindle	\$CALL	86025
Axle Options		
Torsion Axles Single Axle Skiff Trailers	\$CALL	
Torsion Axles Single Axle Trailers 2600lbs-3525lbs. Capacity	\$CALL	
Torsion Axles Tandem Axle Trailers 3600lbs.-7450lbs. Capacity	\$CALL	
Torsion Axles Tandem Axle Trailers 7900lbs.-8725lbs. Capacity	\$CALL	
Torsion Axles Triple Axle Trailers up to 12,625lbs. Capacity	\$CALL	
<i>*Cannot do torsion axles on pontoon and tritoon models</i>		
Ski Boat Set Up		
Ski Boat set up includes rear ski boat crossmember, alternate front crossmember and target bunks where applicable.		
Single and Tandem Axle Aluminum Bunk Trailers	\$CALL	
Triple Axle Aluminum Bunk Trailers and all COM single, tandem, triple axle models	\$CALL	
Single, Tandem and Triple Axle Steel Bunk Trailers	\$CALL	



Spare Tires

Galvanized Steel Belted Bias					
Part #	Description	Lugs	Rim Type	Rim Style	
30002	4.80x12LRC	4	Galv.	Spoke	\$CALL
30003	4.80x12LRC	5	Galv.	Spoke	\$CALL
30010	5.30x12LRC	5	Galv.	Spoke	\$CALL
30020	5.30x12LRD	5	Galv.	Spoke	\$CALL
30151	20.5x8.0x10LRD	5	Galv.	Spoke	\$CALL
30156	20.5x8.0x10LRF	5	Galv.	Spoke	\$CALL
Aluminum Steel Belted Bias					
Part #	Description	Lugs	Rim Type		
30004	4.80x12LRC	4	Aluminum	Star Mag	\$CALL
30005	4.80x12LRC	5	Aluminum	Avalanche Black	\$CALL
30008	5.30x12LRC	5	Aluminum	Avalanche Black	\$CALL
30014	5.30x12LRD	5	Aluminum	Avalanche Black	\$CALL
30152	205/65-10 LRD <small>(used to replace 20.5x8x10 LRD)</small>	5	Aluminum	Split Spoke	\$CALL
30161	205/65-10 LRF <small>(used to replace 20.5x8x10 LRF)</small>	5	Aluminum	Avalanche Black	\$CALL
Galvanized Radial					
Part #	Description	Lugs	Rim Type		
35000	ST145/R12LRE Radial	5	Galv.	Spoke	\$CALL
35010	ST175/80R13LRC Radial	5	Galv.	Spoke	\$CALL
35020	ST175/80R13LRD Radial	5	Galv.	Spoke	\$CALL
35030	ST185/80R13LRC Radial	5	Galv.	Spoke	\$CALL
35040	ST185/80R13LRD Radial	5	Galv.	Spoke	\$CALL
35060	ST205/75R14LRC Radial	5	Galv.	Spoke	\$CALL
35090	ST205/75R15LRC Radial	5	Galv.	Spoke	\$CALL
35110	ST215/75R14LRC Radial	5	Galv.	Spoke	\$CALL
35130	ST225/75R15LRD Radial	5	Galv.	Spoke	\$CALL
35150	ST225/75R15LRD Radial	6	Galv.	Spoke	\$CALL
35170	ST225/75R15LRE Radial	6	Galv.	Spoke	\$CALL
35190	ST235/80R16LRE Radial	8	Galv.	Spoke	\$CALL
Aluminum Radial					
Part #	Description	Lugs	Rim Type		
35005	ST145/R12LRE Radial	5	Aluminum	Avalanche Black	\$CALL
35014	ST175/80R13LRC Radial	5	Aluminum	A1411 Gunmetal	\$CALL
35024	ST175/80R13LRD Radial	5	Aluminum	A1411 Gunmetal	\$CALL
35034	ST185/80R13LRC Radial	5	Aluminum	A1411 Gunmetal	\$CALL
35044	ST185/80D13LRD Radial	5	Aluminum	A1411 Gunmetal	\$CALL
35064	ST205/75R14LRC Radial	5	Aluminum	A1411 Gunmetal	\$CALL
35084	ST205/75R14LRD Radial	5	Aluminum	A1411 Gunmetal	\$CALL
35114	ST215/75R14LRC Radial	5	Aluminum	A1411 Gunmetal	\$CALL
35094	ST205/75R15LRC Radial	5	Aluminum	A1411 Gunmetal	\$CALL
35134	ST225/75R15LRD Radial	5	Aluminum	A1411 Gunmetal	\$CALL
35154	ST225/75R15LRD Radial	6	Aluminum	A1411 Gunmetal	\$CALL
35174	ST225/75R15LRE Radial	6	Aluminum	A1411 Gunmetal	\$CALL
35194	ST235/80R16LRE Radial	8	Aluminum	A1411 Gunmetal	\$CALL
Commander Line Aluminum Radial					
Part #	Description	Lugs	Rim Type		
35063	Tire ST205/75R14 LRC 5H	5	Aluminum	Aluminum-A1411 Black	\$CALL
35113	Tire ST215/75R14 LRC 5H	5	Aluminum	Aluminum-A1411 Black	\$CALL
35133	Tire ST225/75R15 LRD 5H	5	Aluminum	Aluminum-A1411 Black	\$CALL
35153	Tire ST225/75R15 LRD 6H	6	Aluminum	Aluminum-A1411 Black	\$CALL

Tredit Advantage

4 Years Roadside Assistance
Coverage FREE
with every trailer!

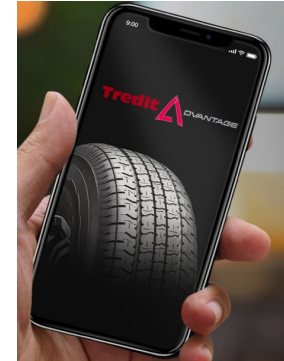

[Click here to find out more about Tredit Advantage](http://www.tredittire.com/tredit-advantage/)

www.tredittire.com/tredit-advantage/

Be sure to advise your customers to register their tire for use of the Tredit Advantage program as well as to be notified of any tire recalls.

